

# Playtime

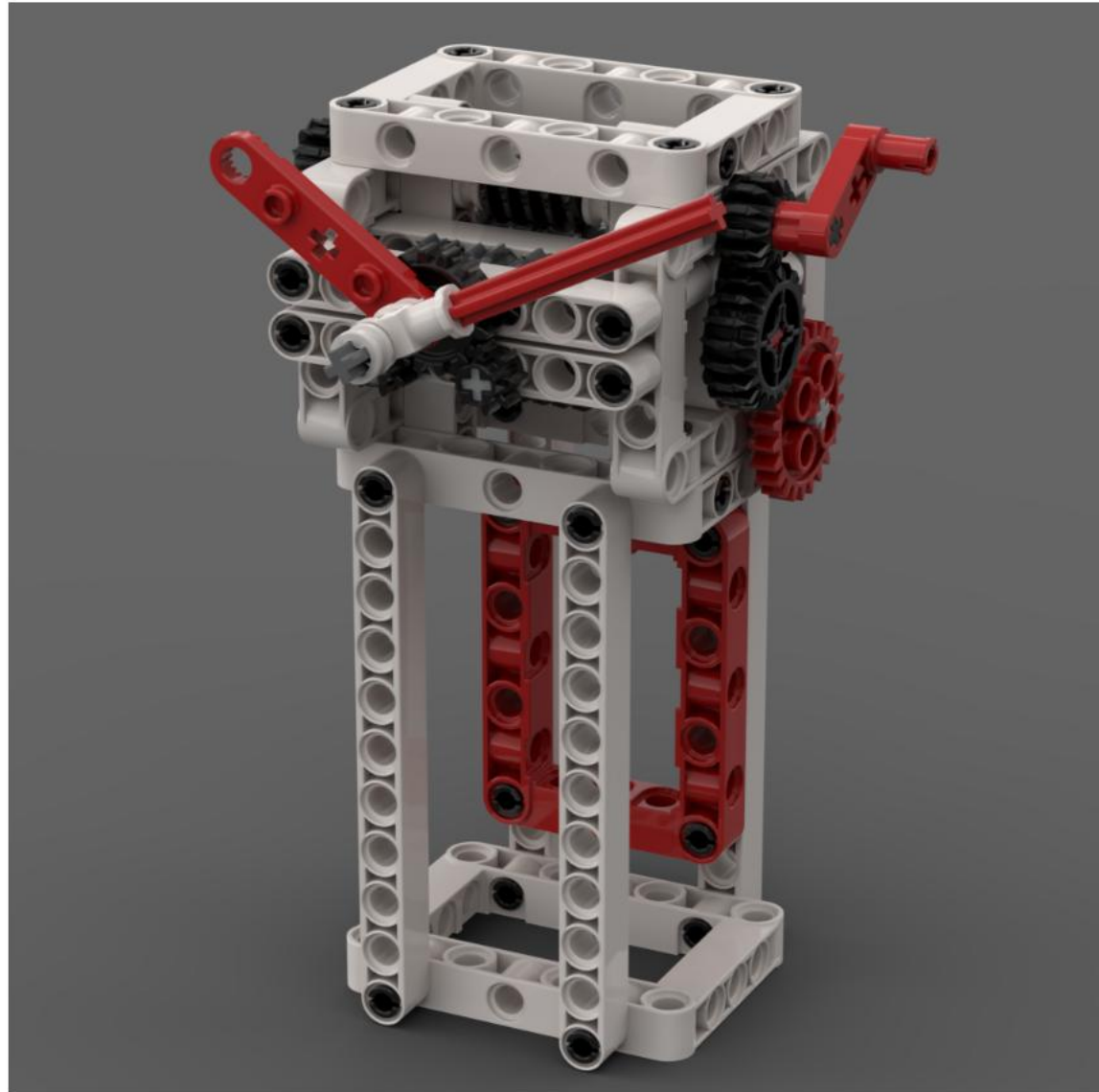

# Playtime

On an analog clock, the minute hand completes one full circumference every hour, while the hour hand advances by one twelfth of the circle. This build models the 1:12 relationship.

While multiple gear pairings could provide the desired gear ratio, this model is designed to be compact. It requires fine motor skills to assemble, immitating the process of assembling a real watch movement. Gear slack is minimized using several techniques: worm gears, redundant gears, and gears placed on friction pins. The end result is mechanically accurate while being aesthetically pleasing with a throwback look. The red and white color schemes were picked to tie back to my Swiss heritage.

I hope you enjoy building this clock as much as I enjoyed designing it!

Alok Menghrajani

1

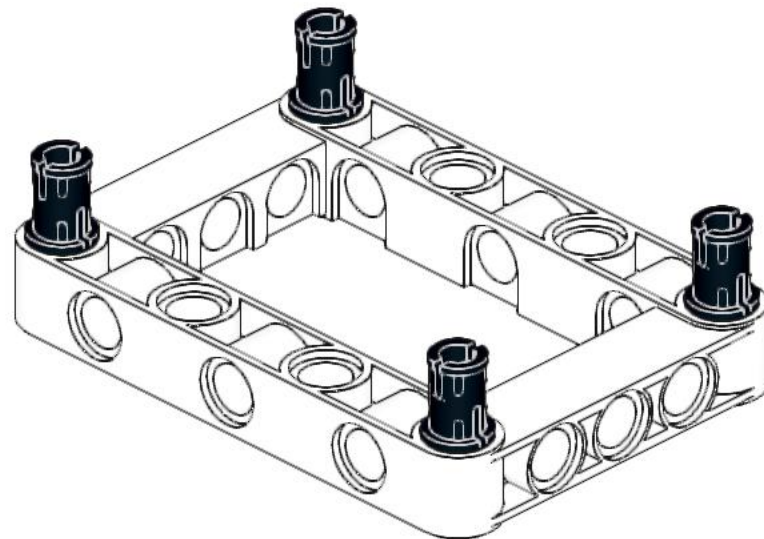
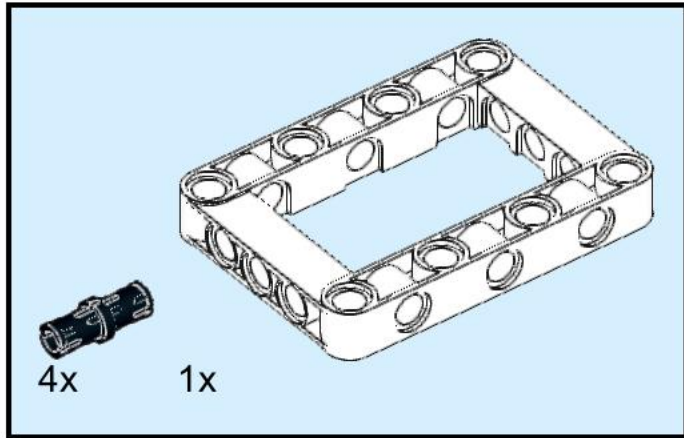

2

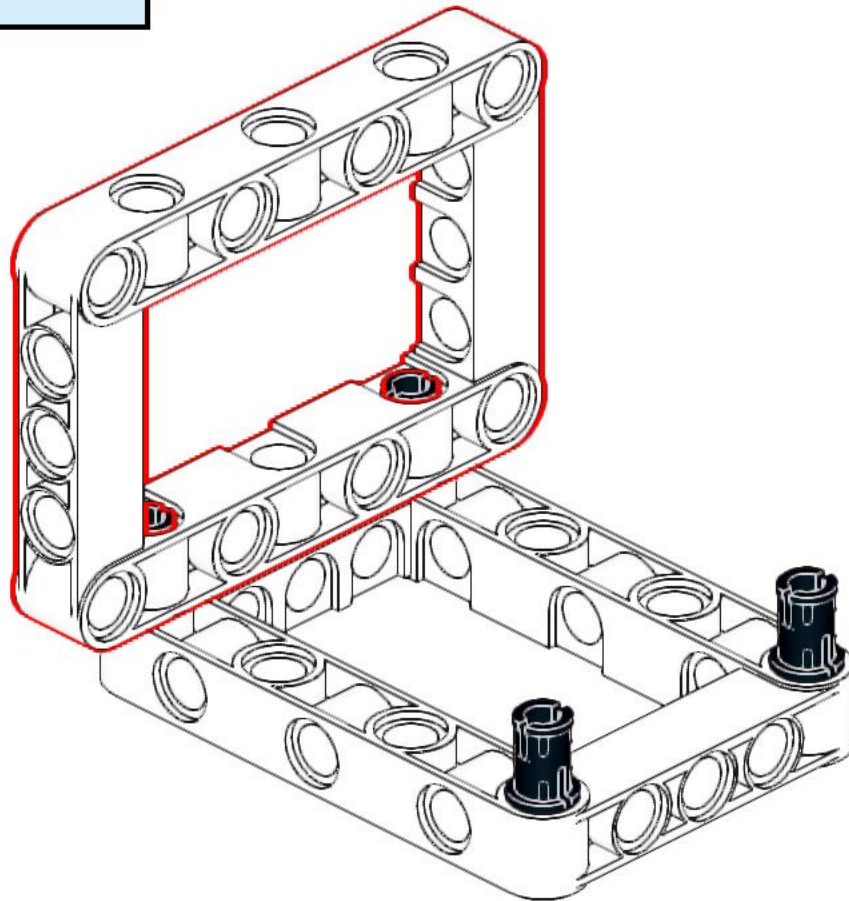
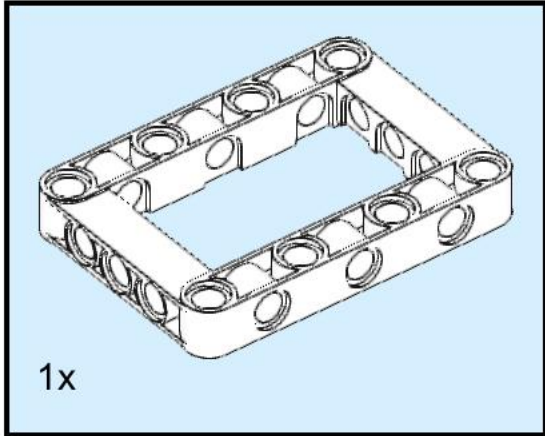

3

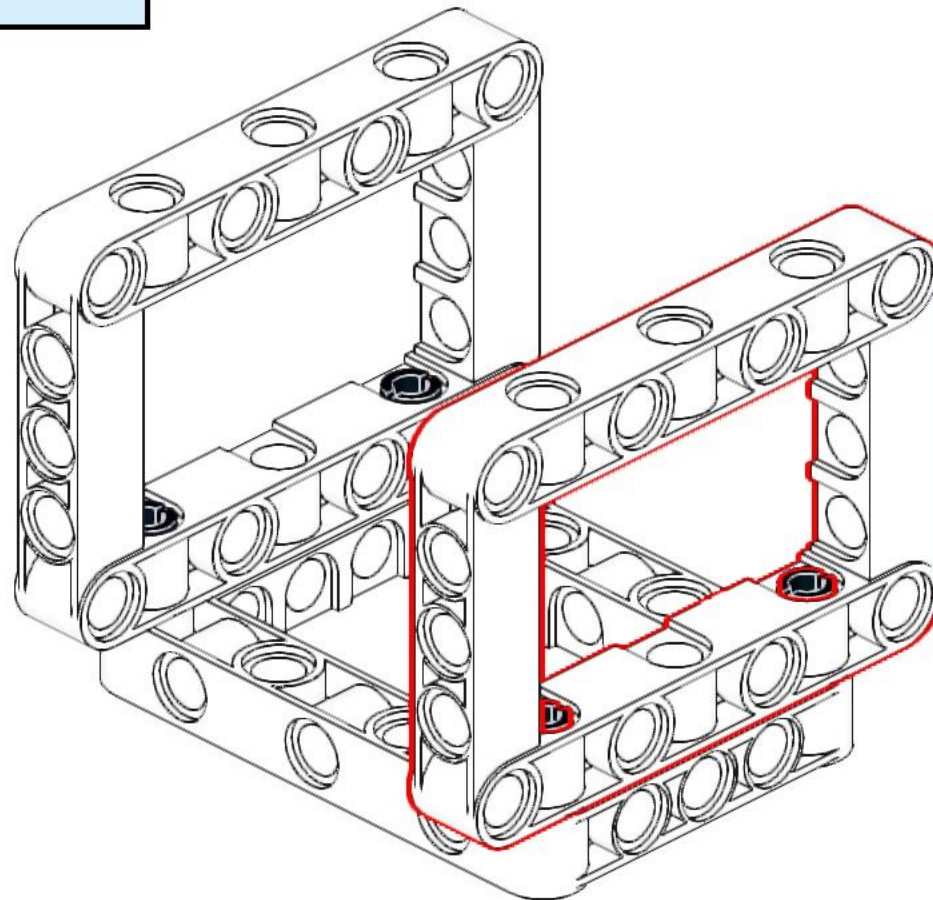
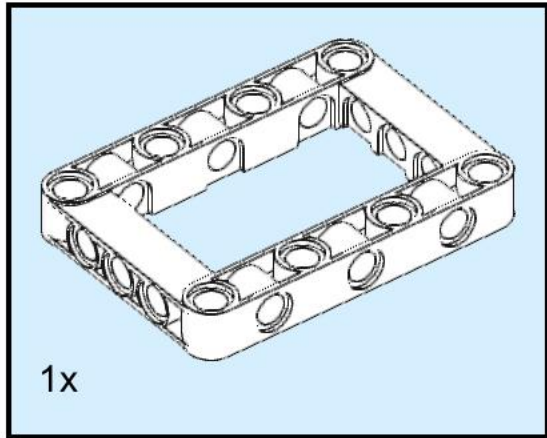

4

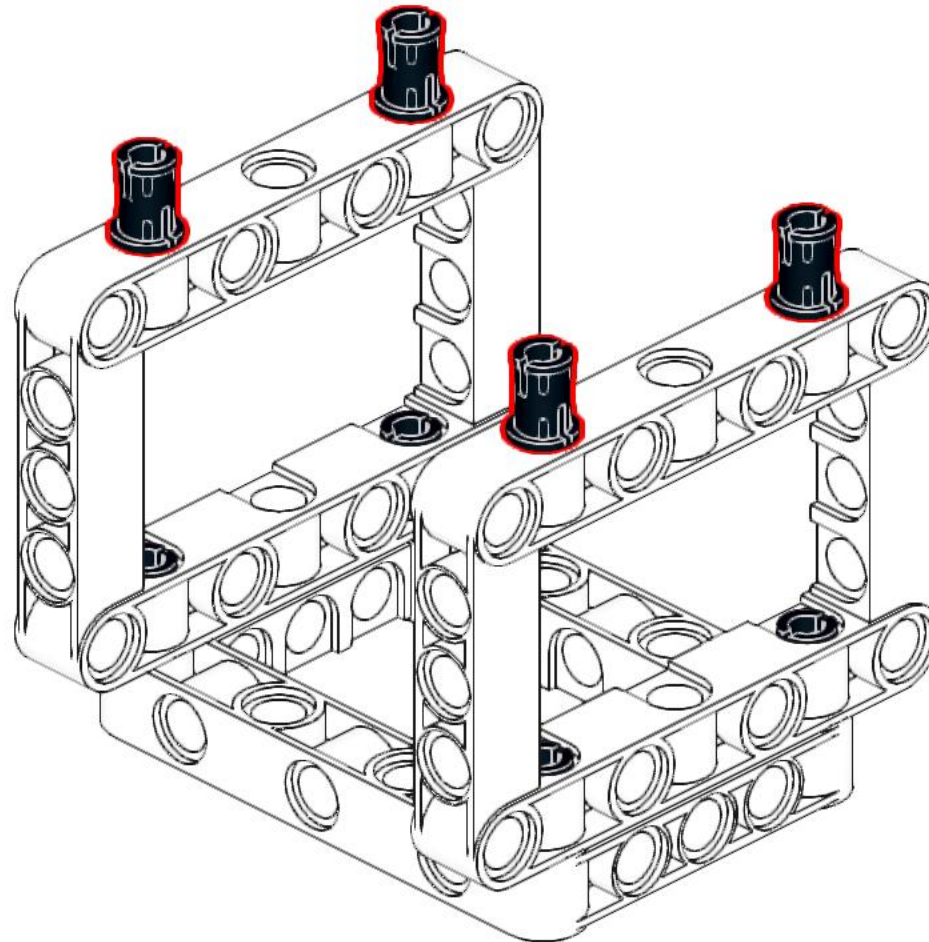

5

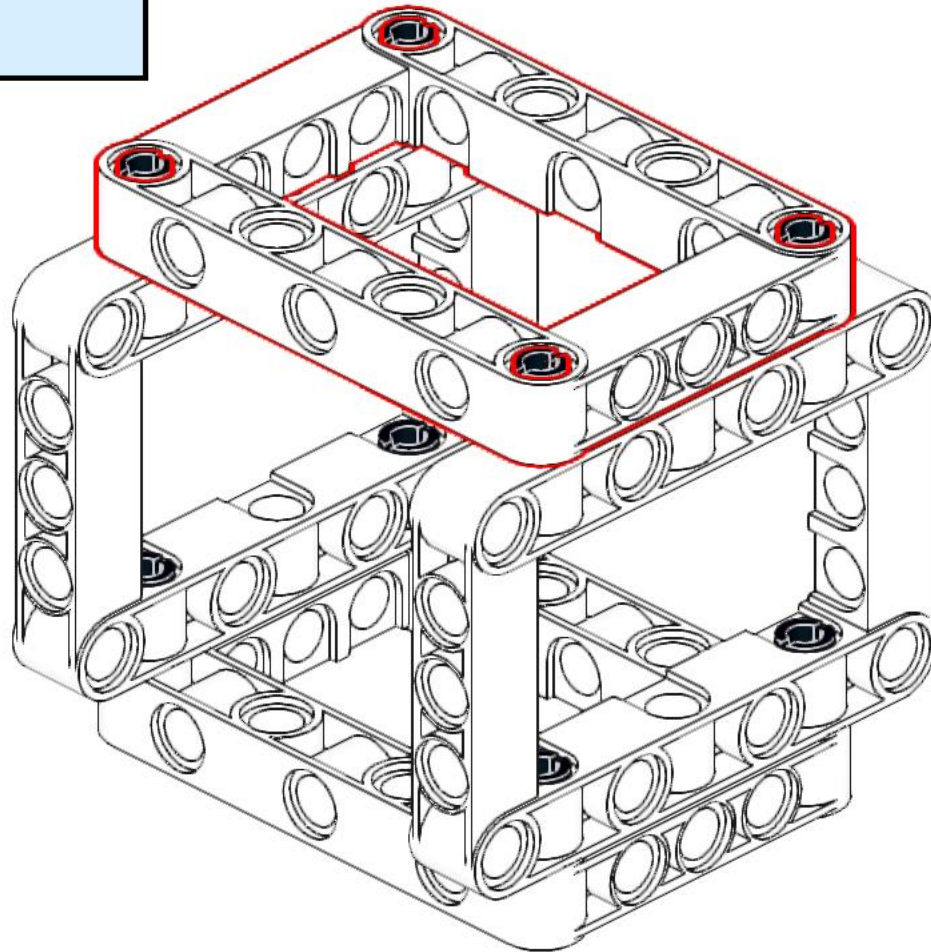
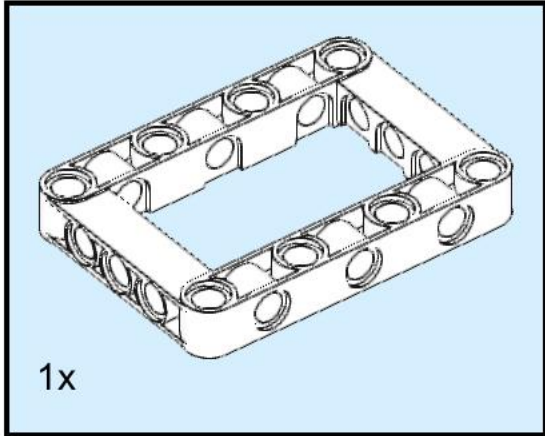

6

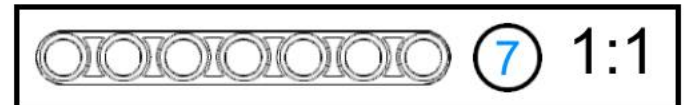
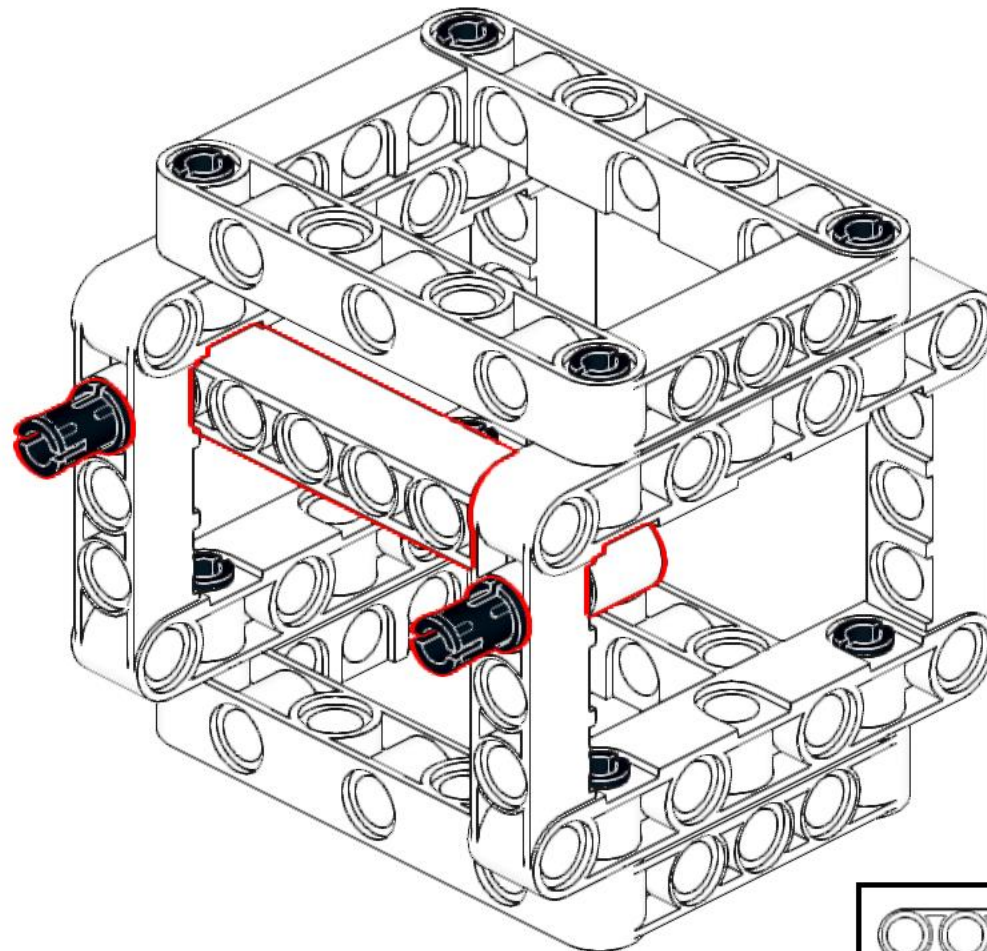
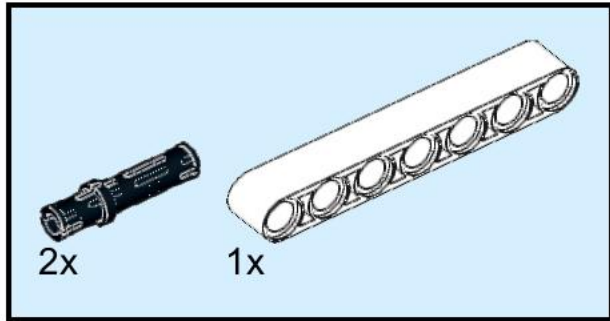

7

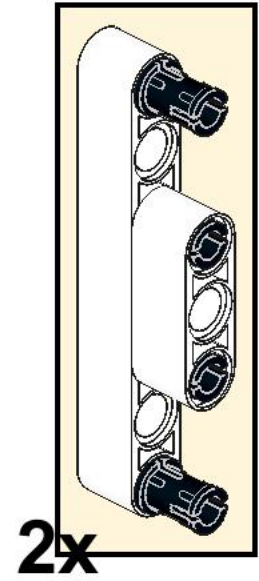
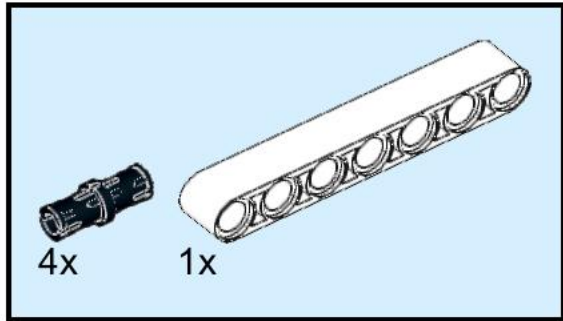

8

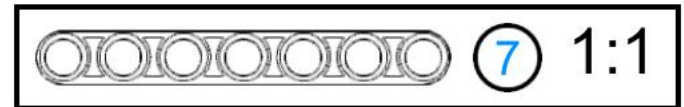
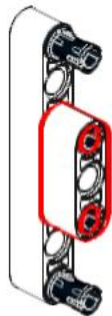
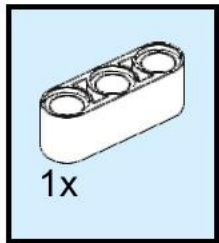

9

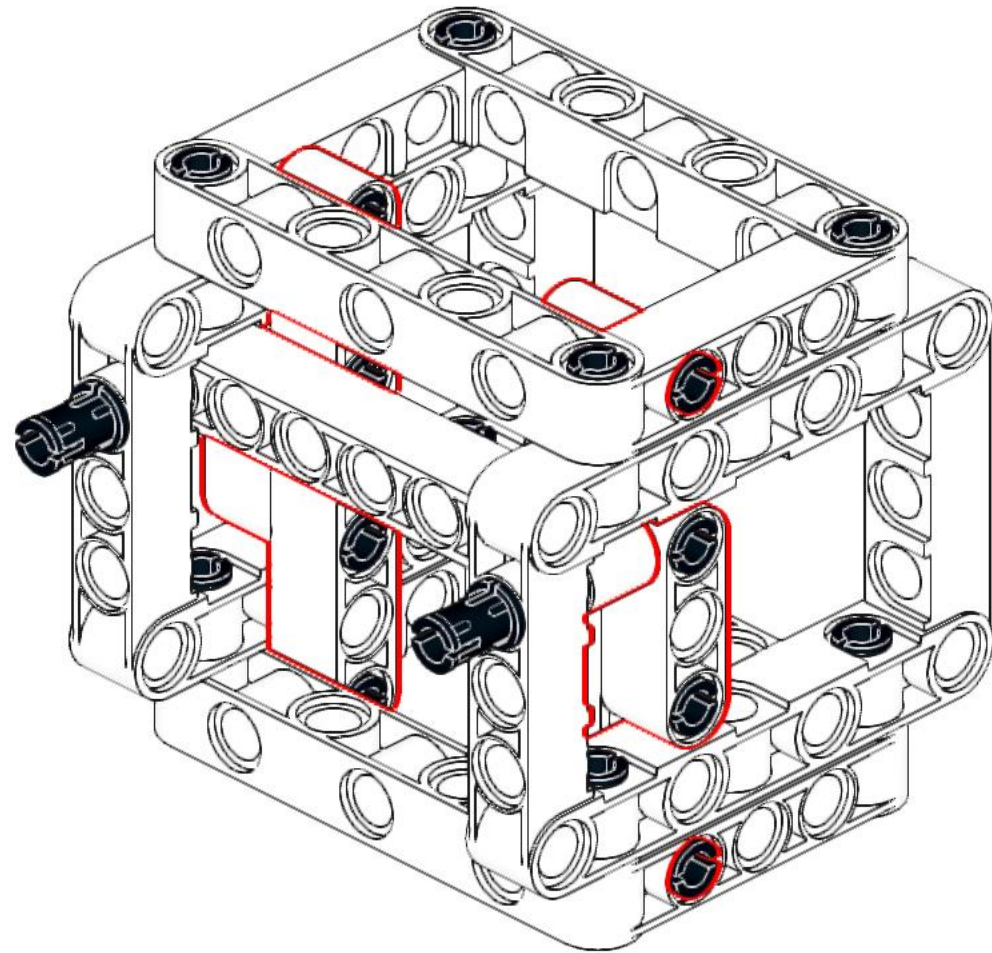

# 10

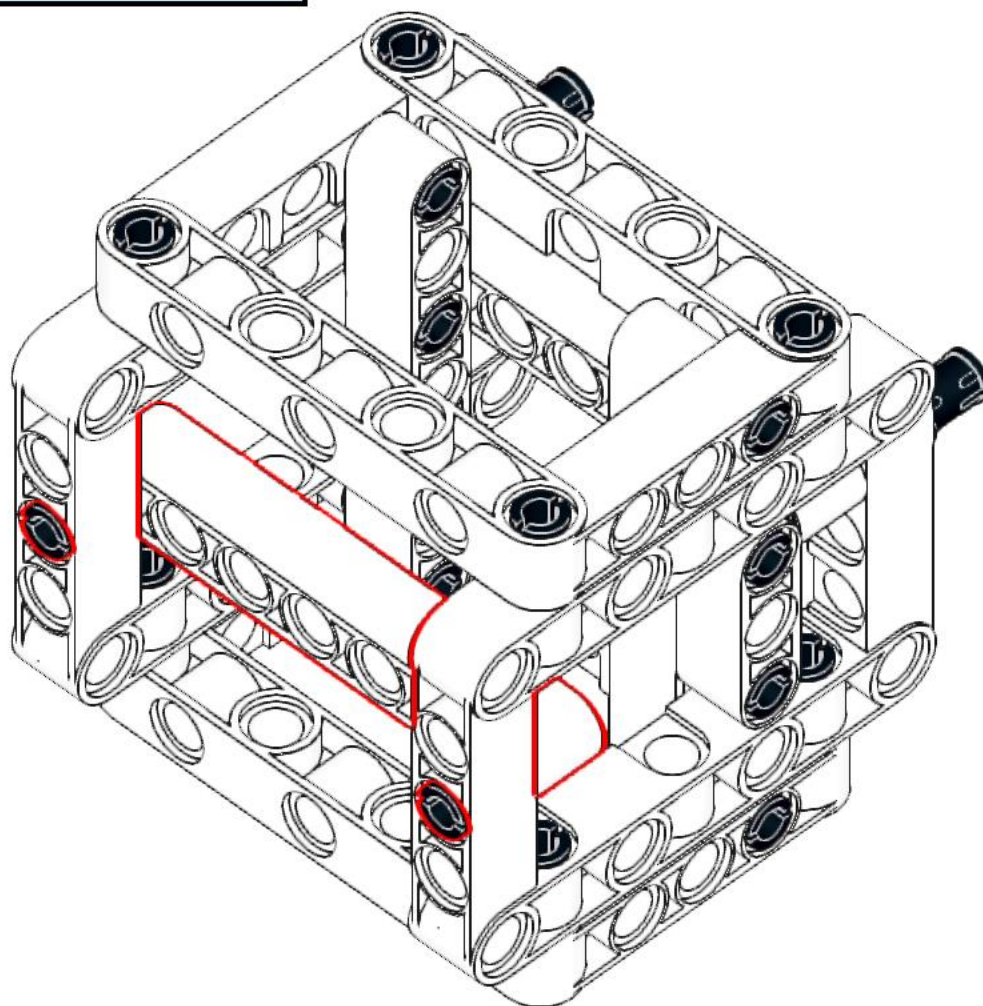
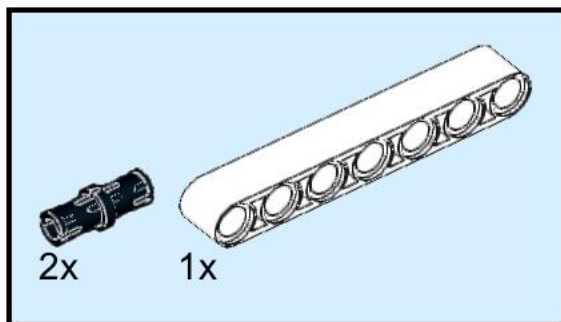

# 11

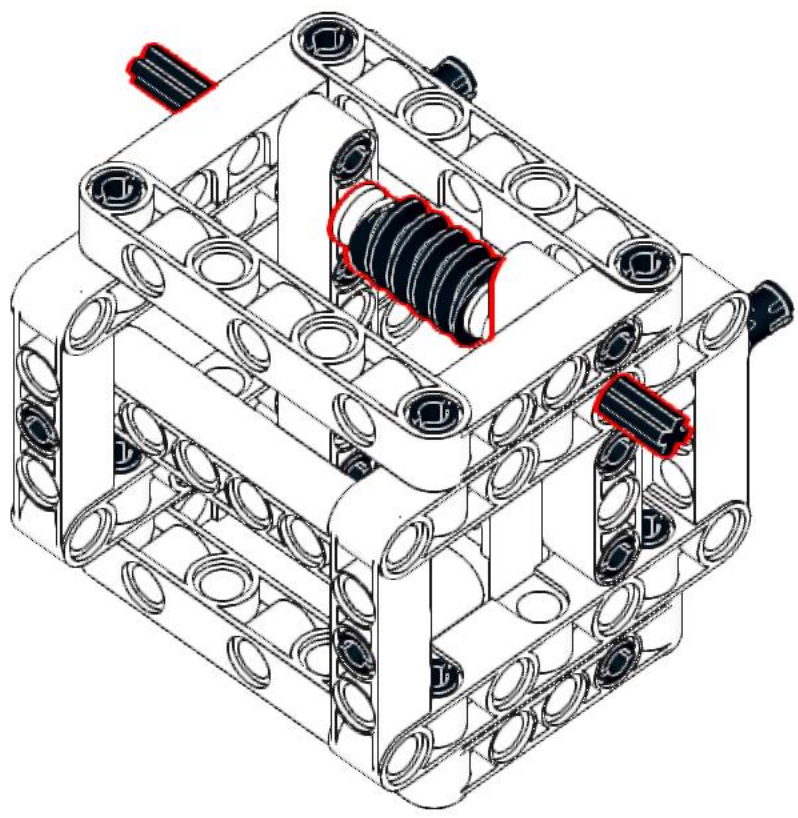
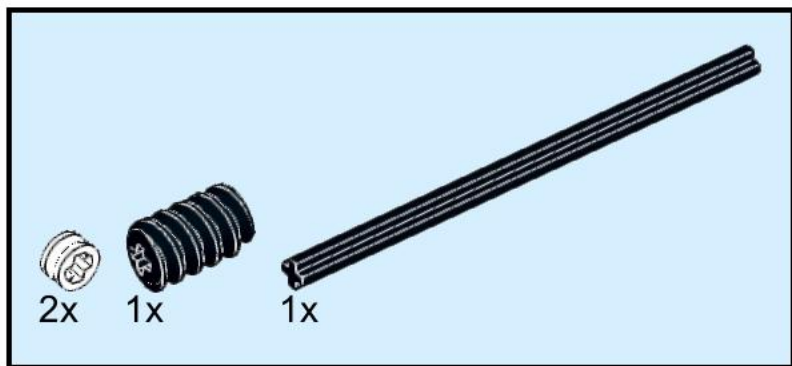

# 12

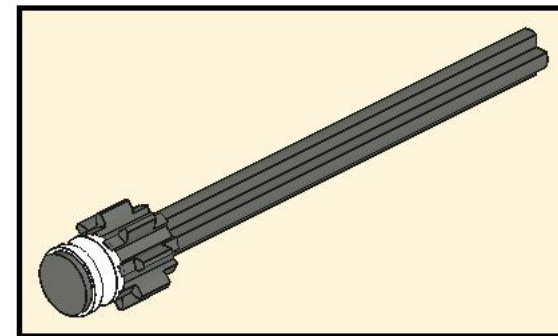
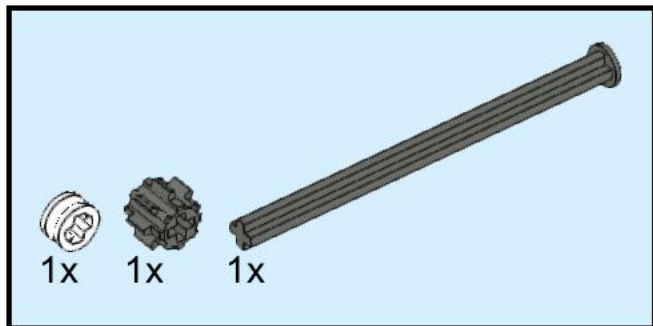

# 13

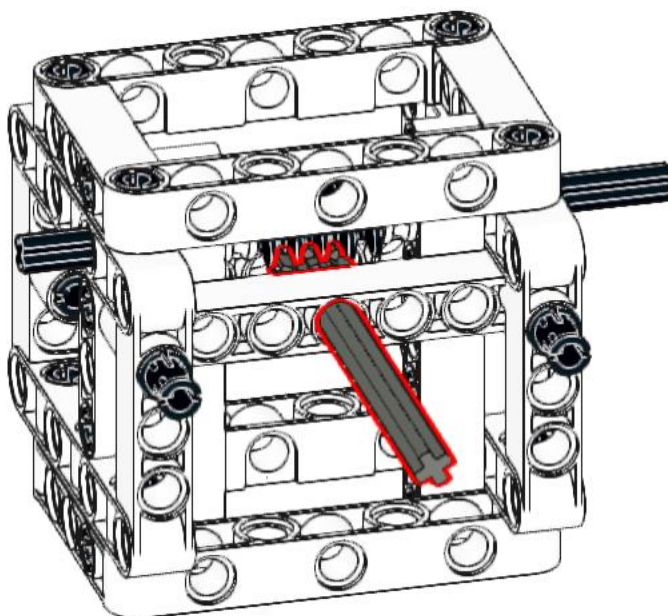

# 14

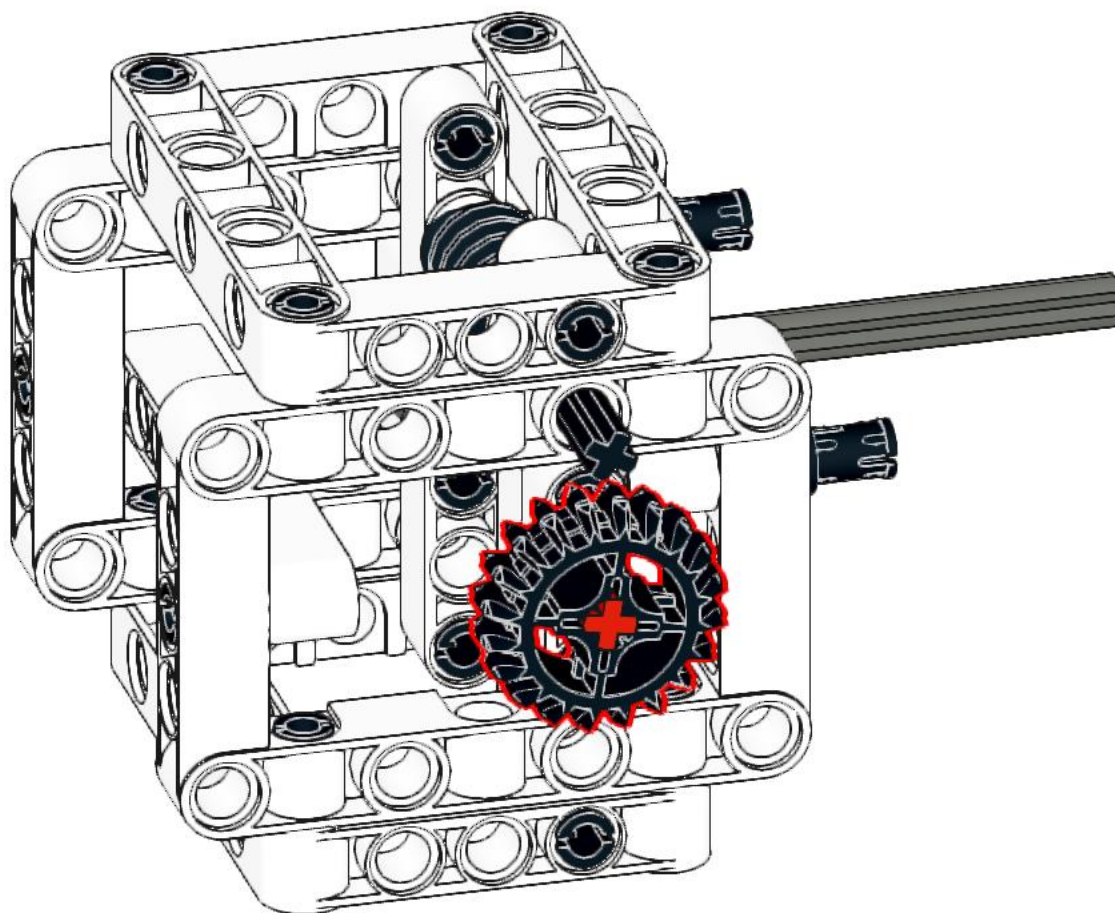
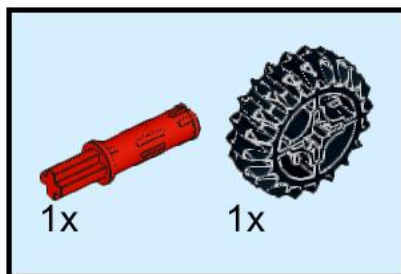

# 15

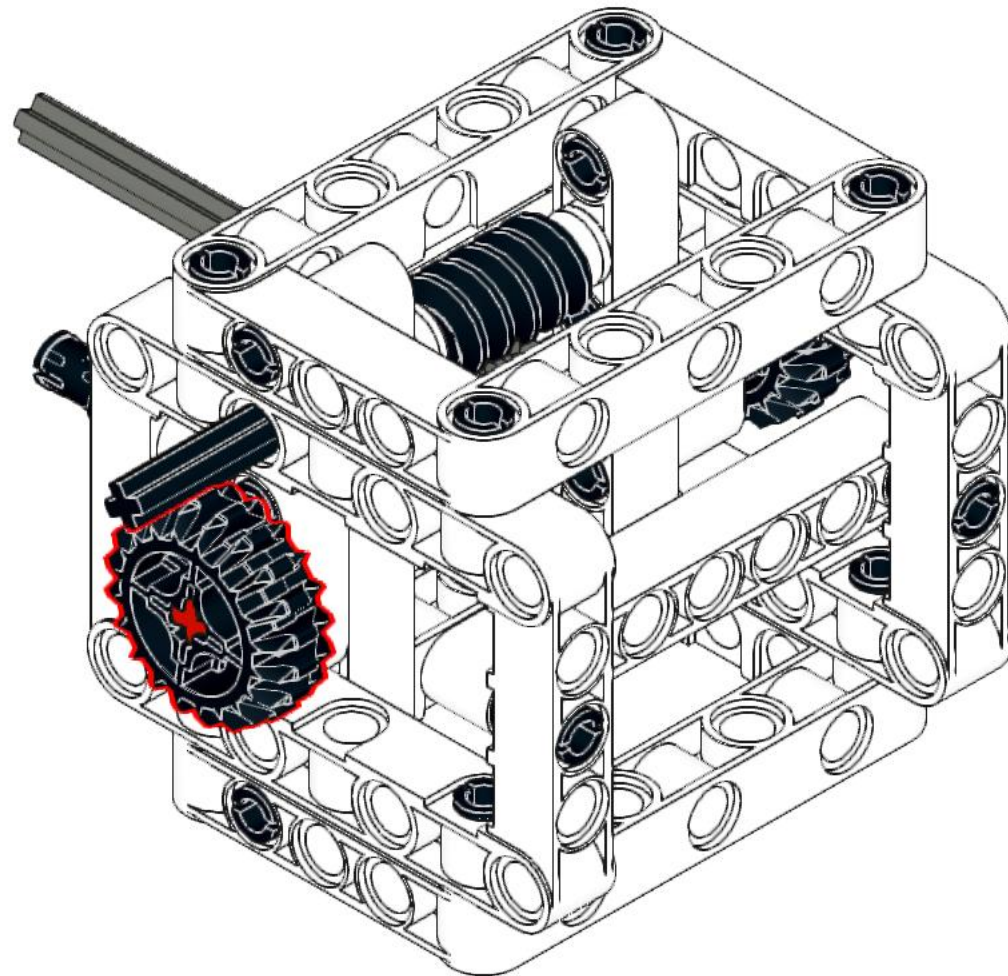
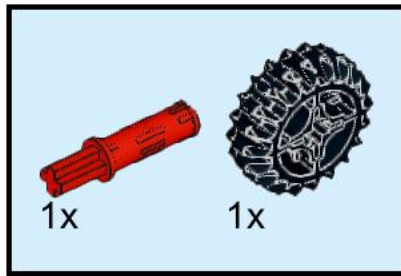

# 16

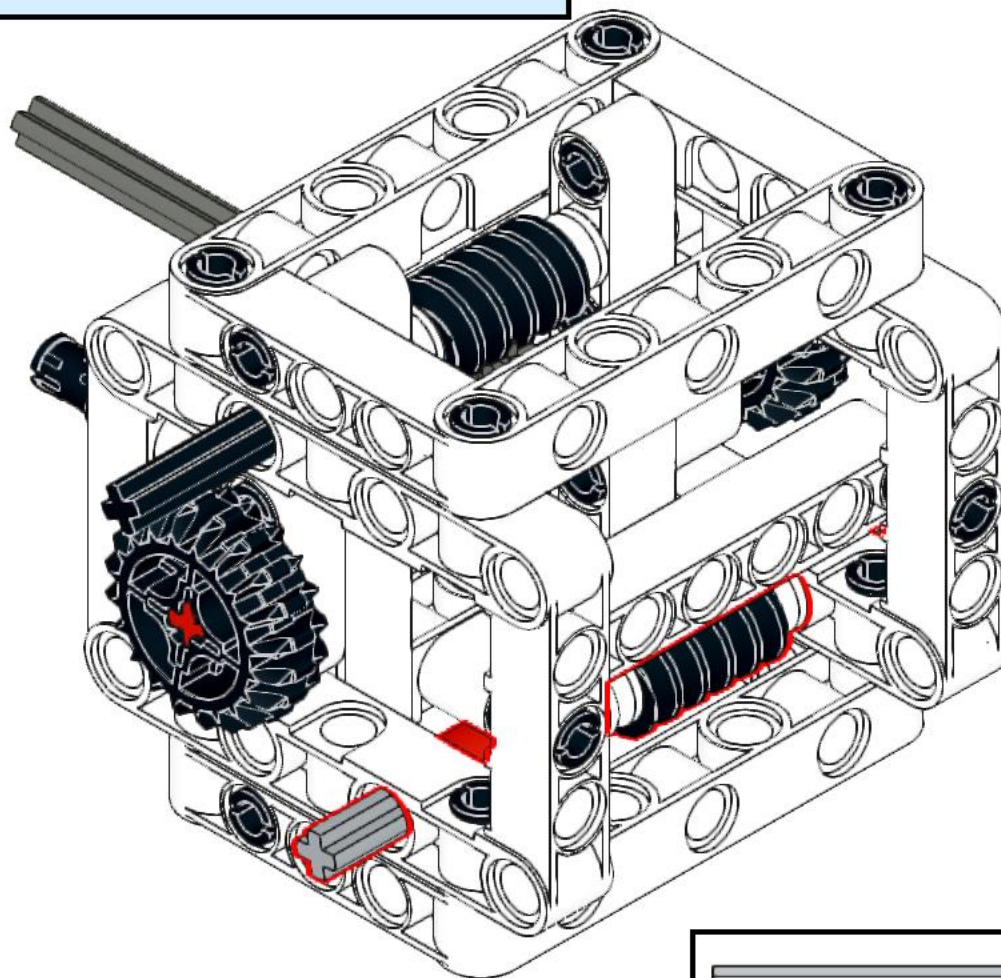
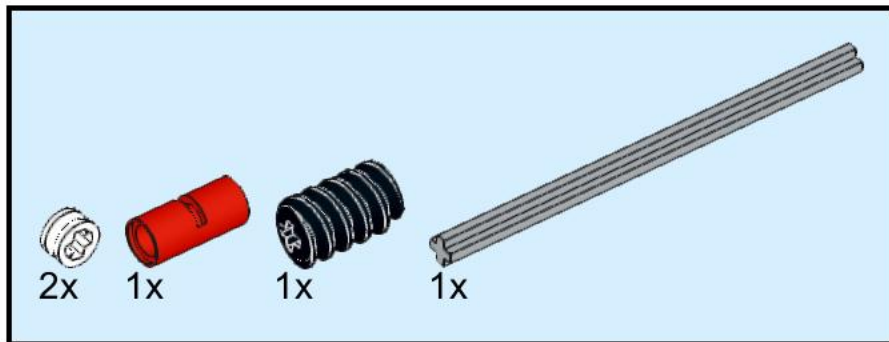

# 17

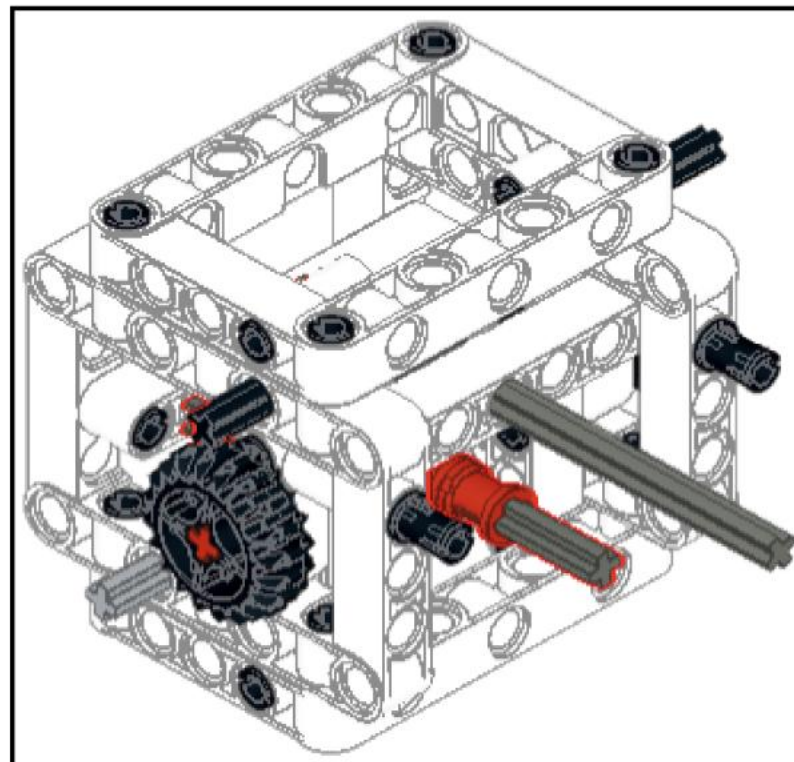
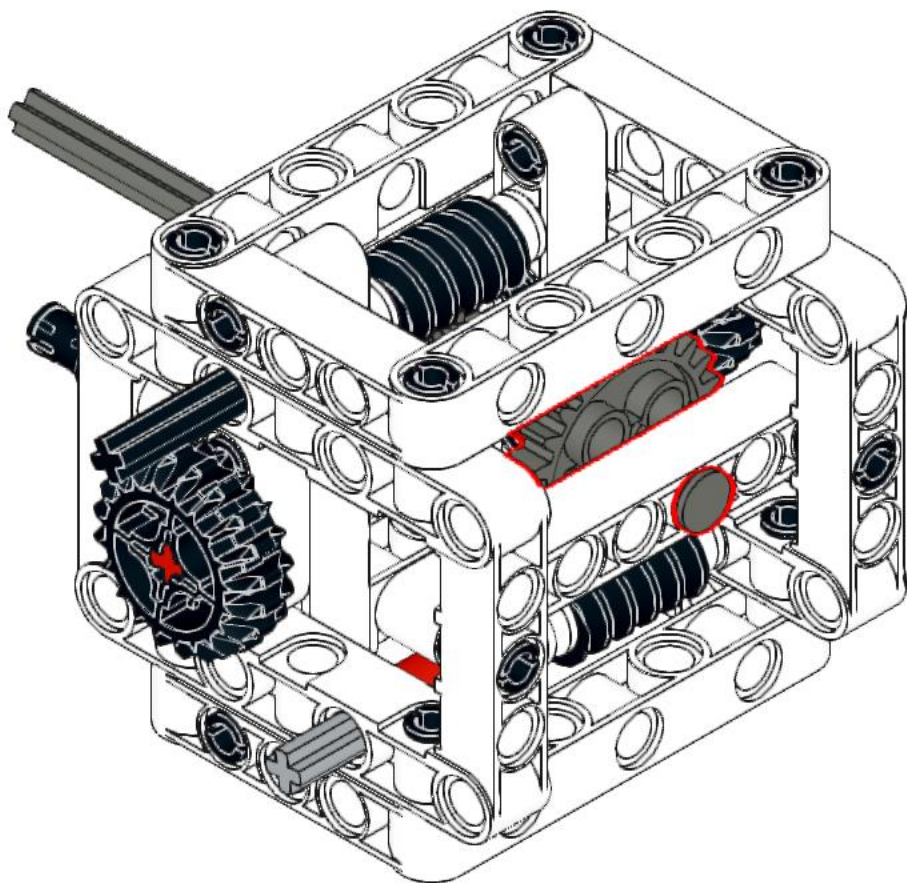
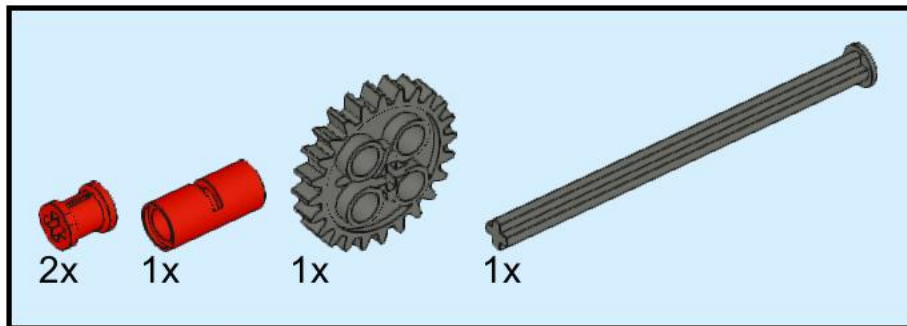

# 18

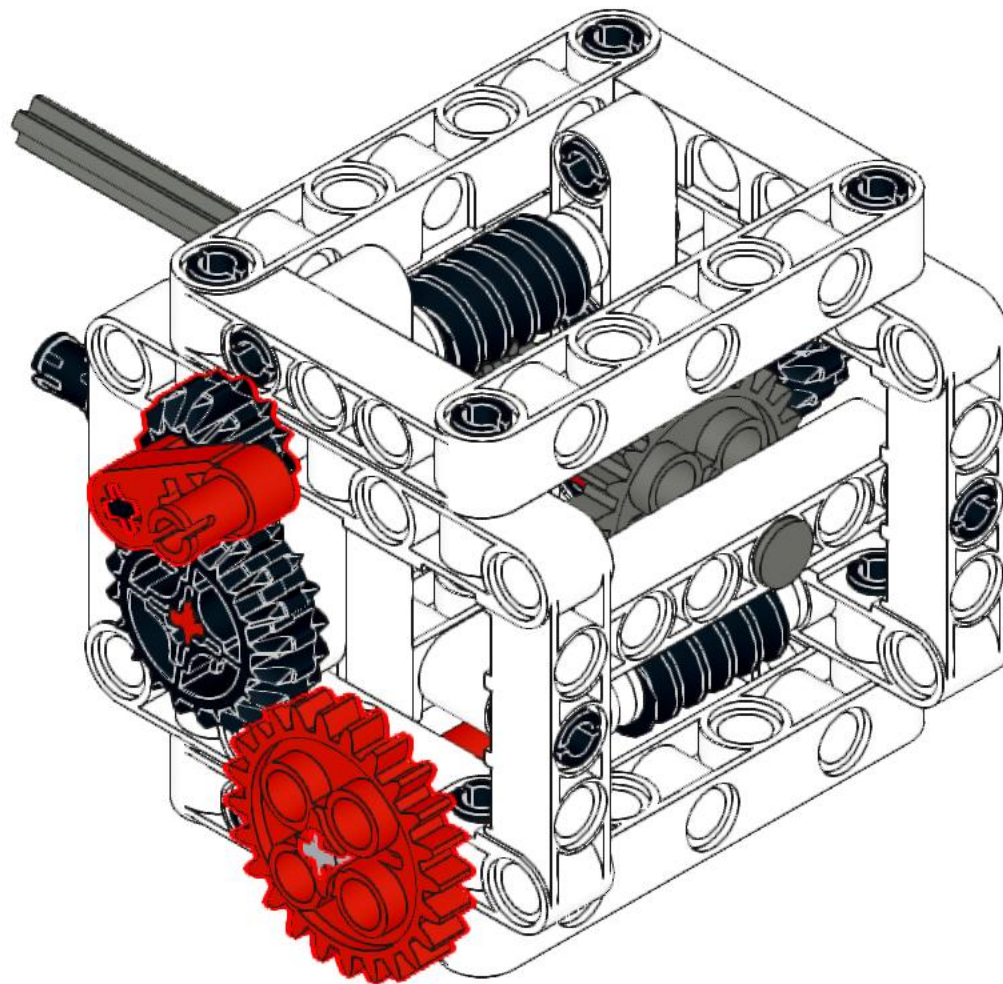
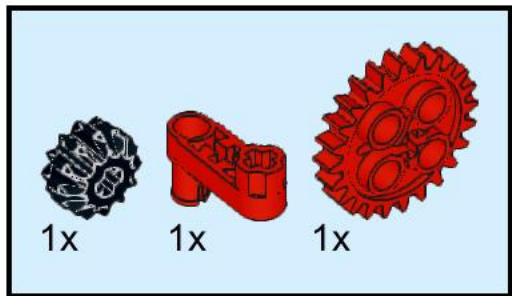

# 19

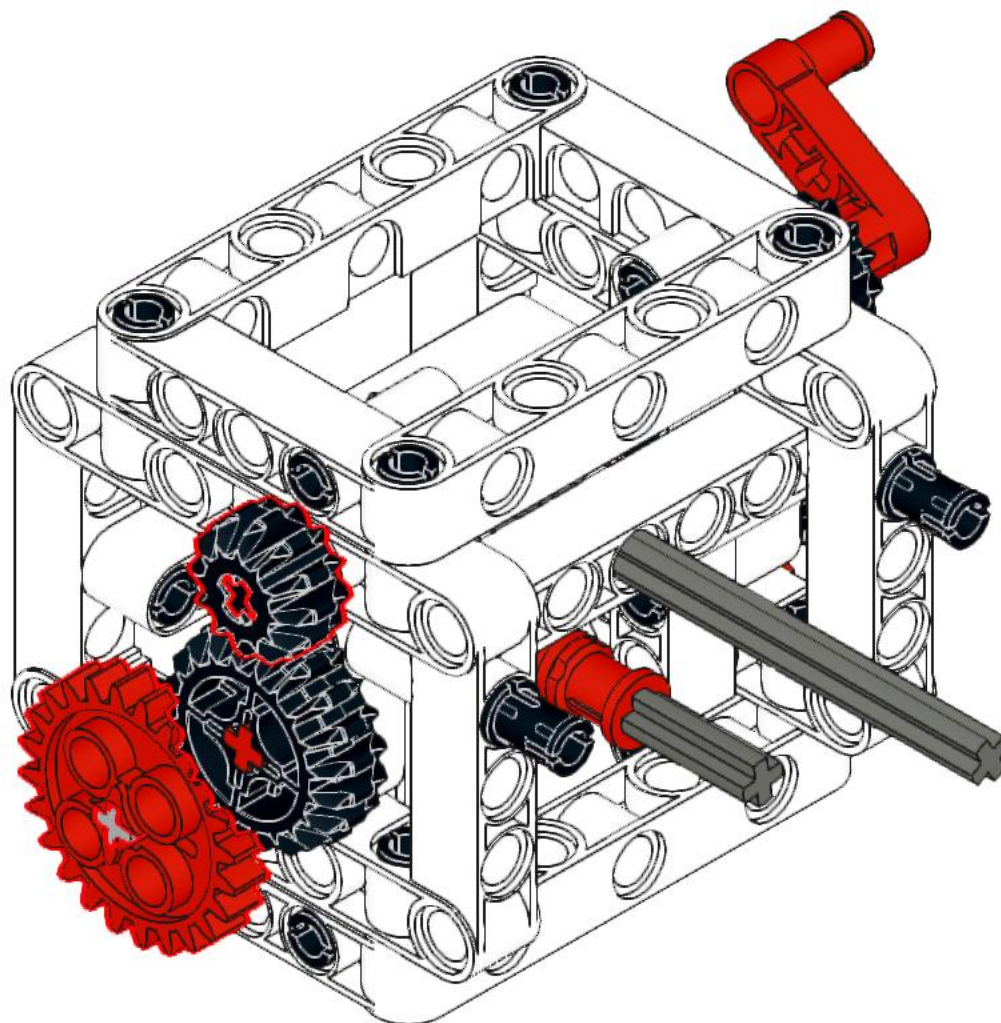
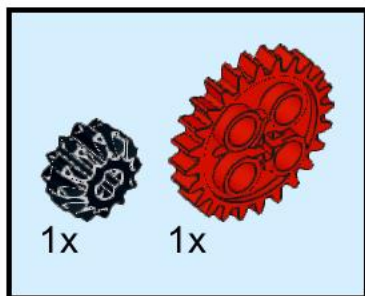

# 20

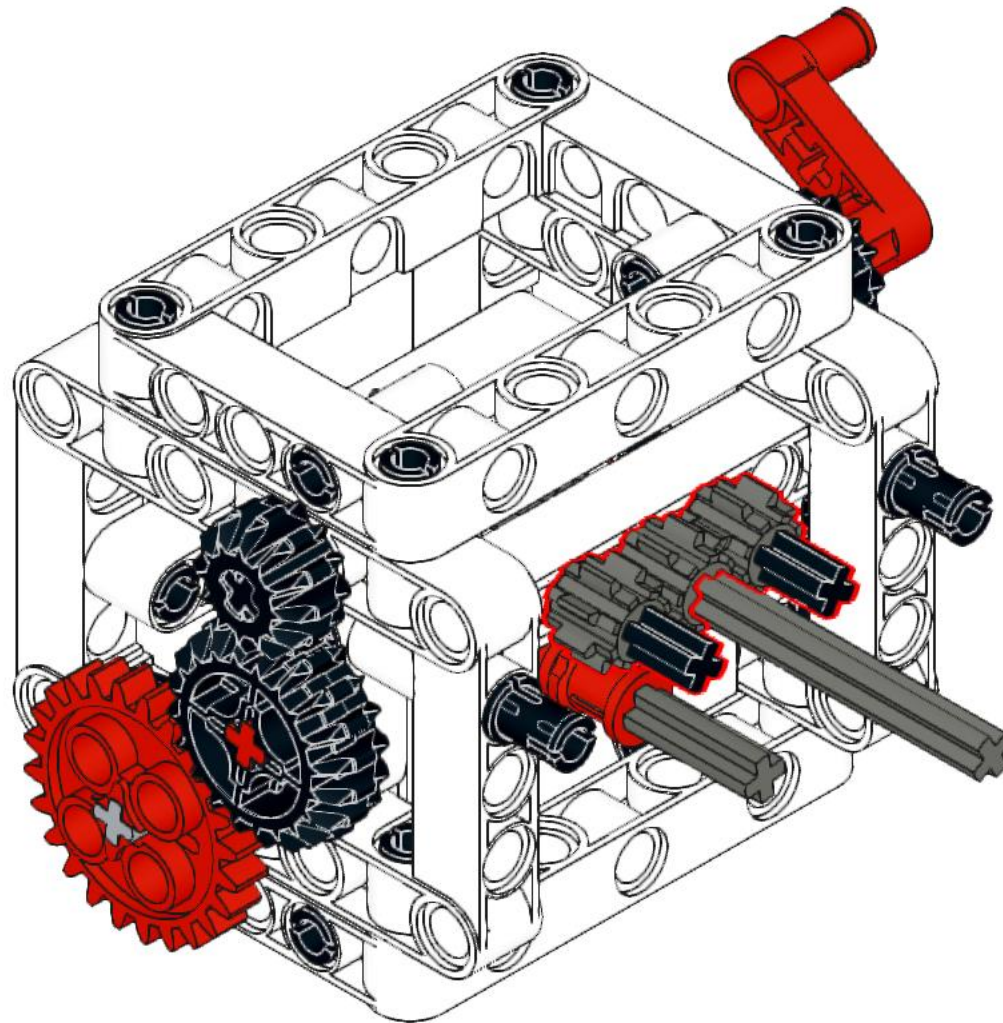
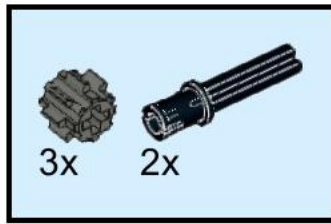

# 21

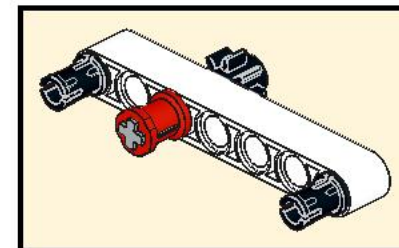
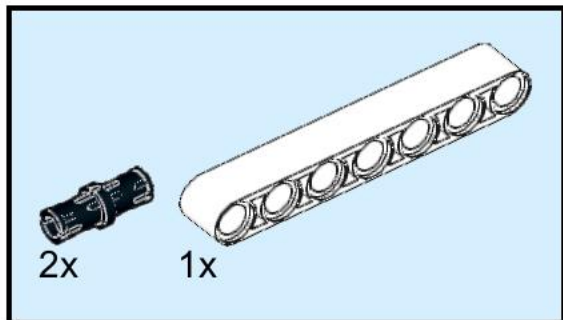

# 22

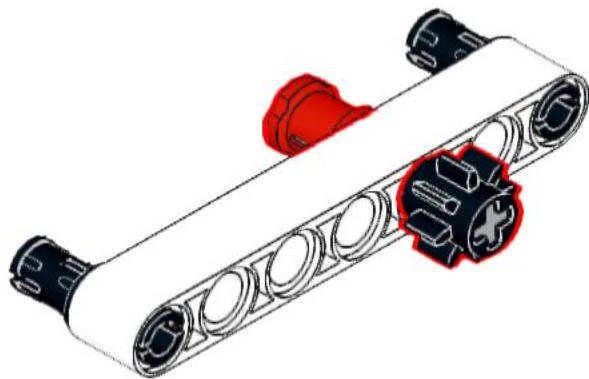
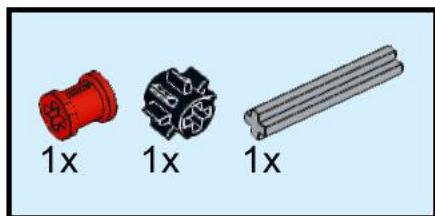

# 23

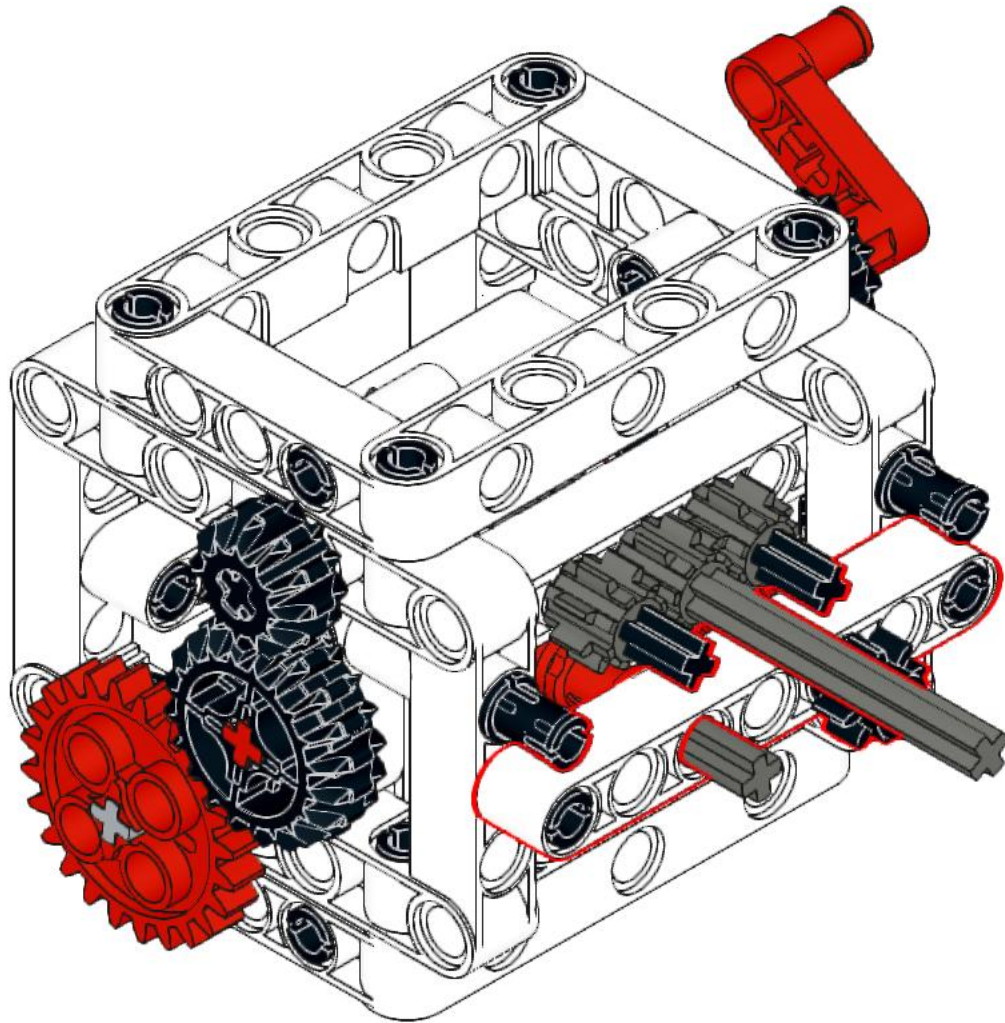

# 24

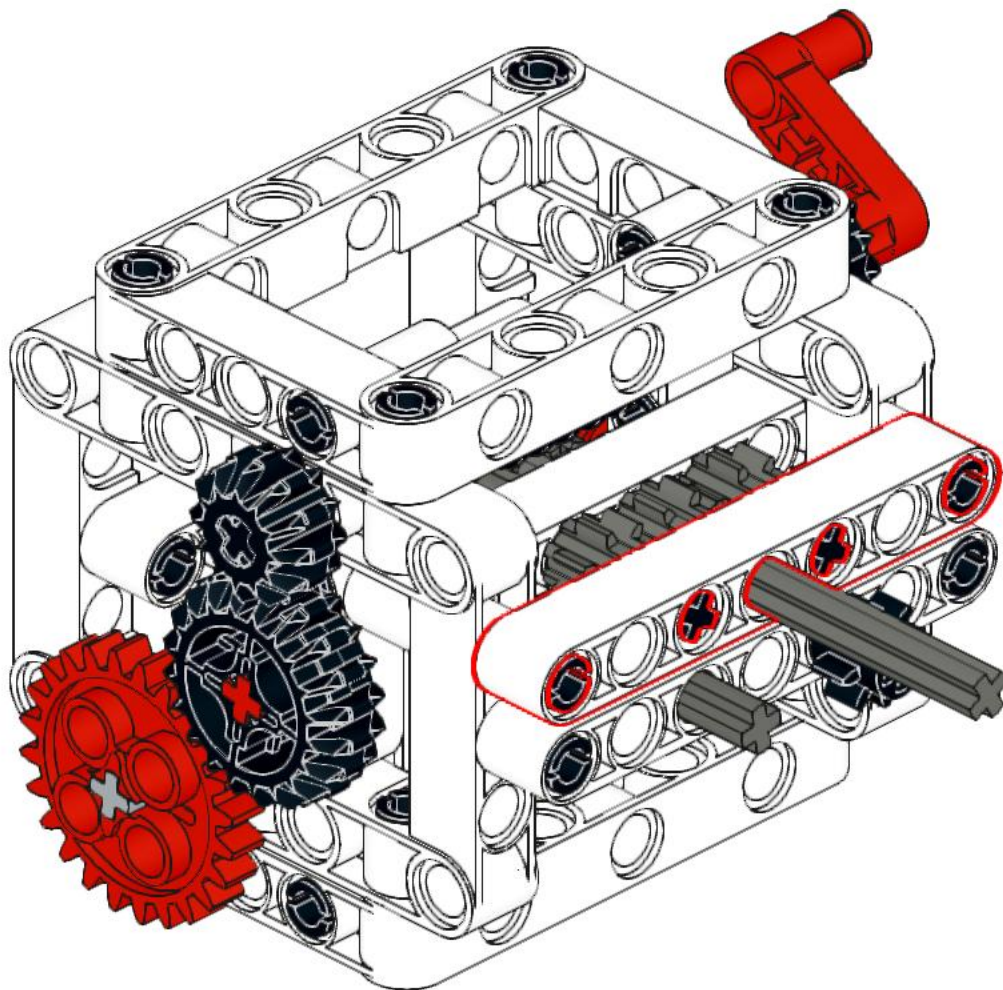
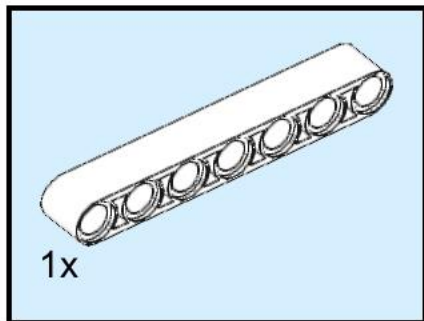

# 25

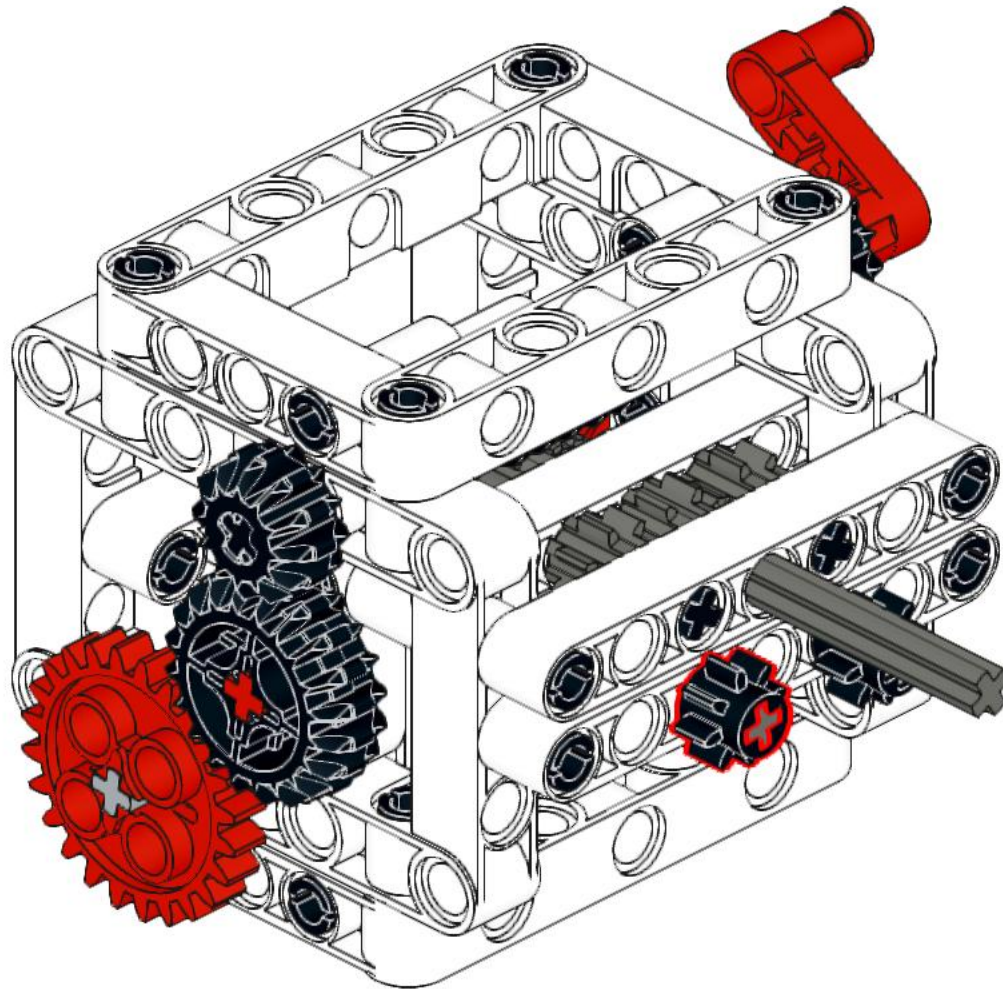

# 26

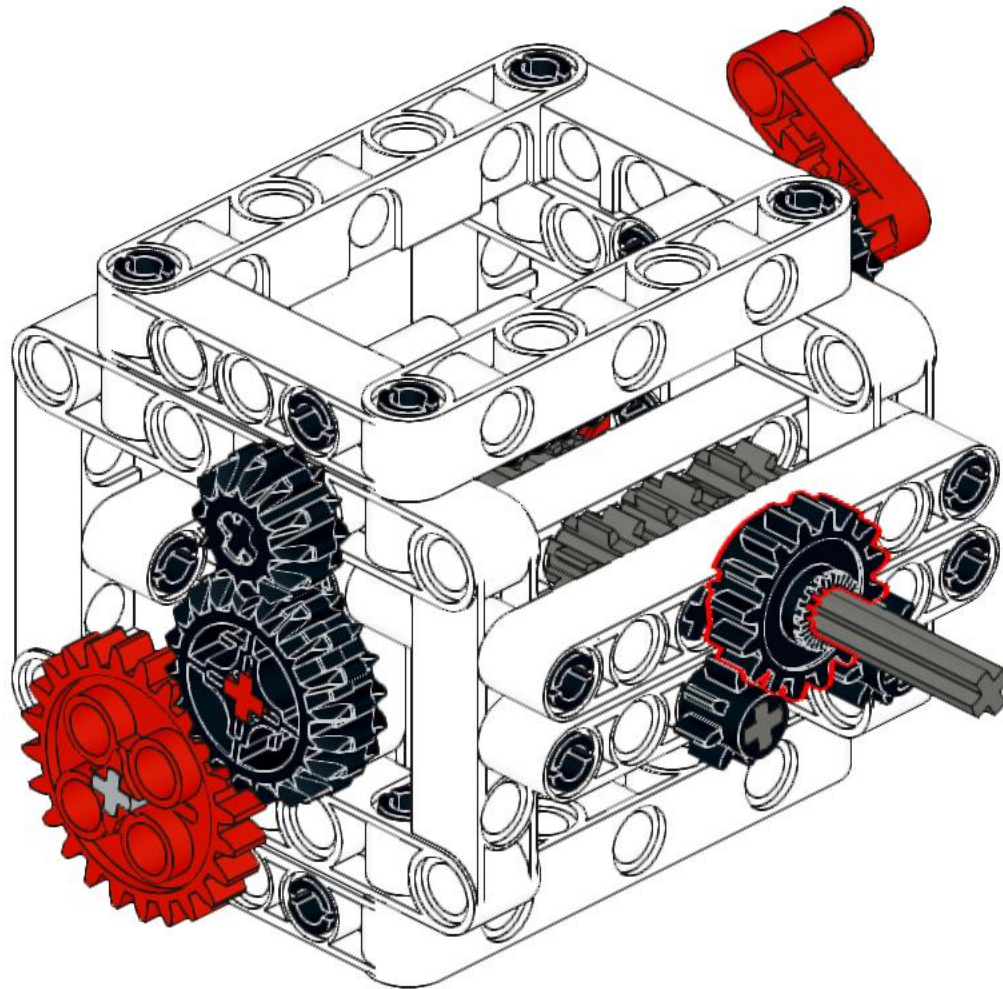

# 27

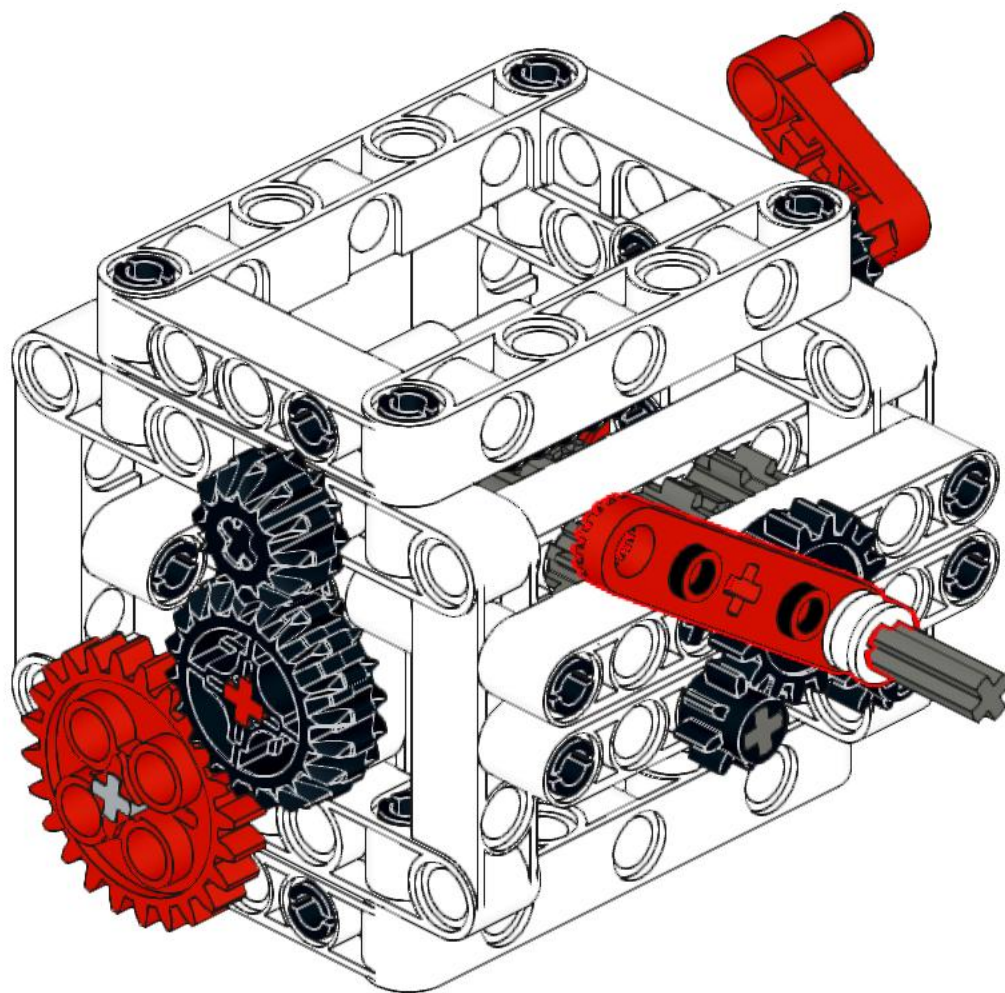
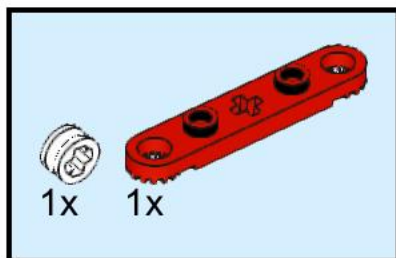

# 28

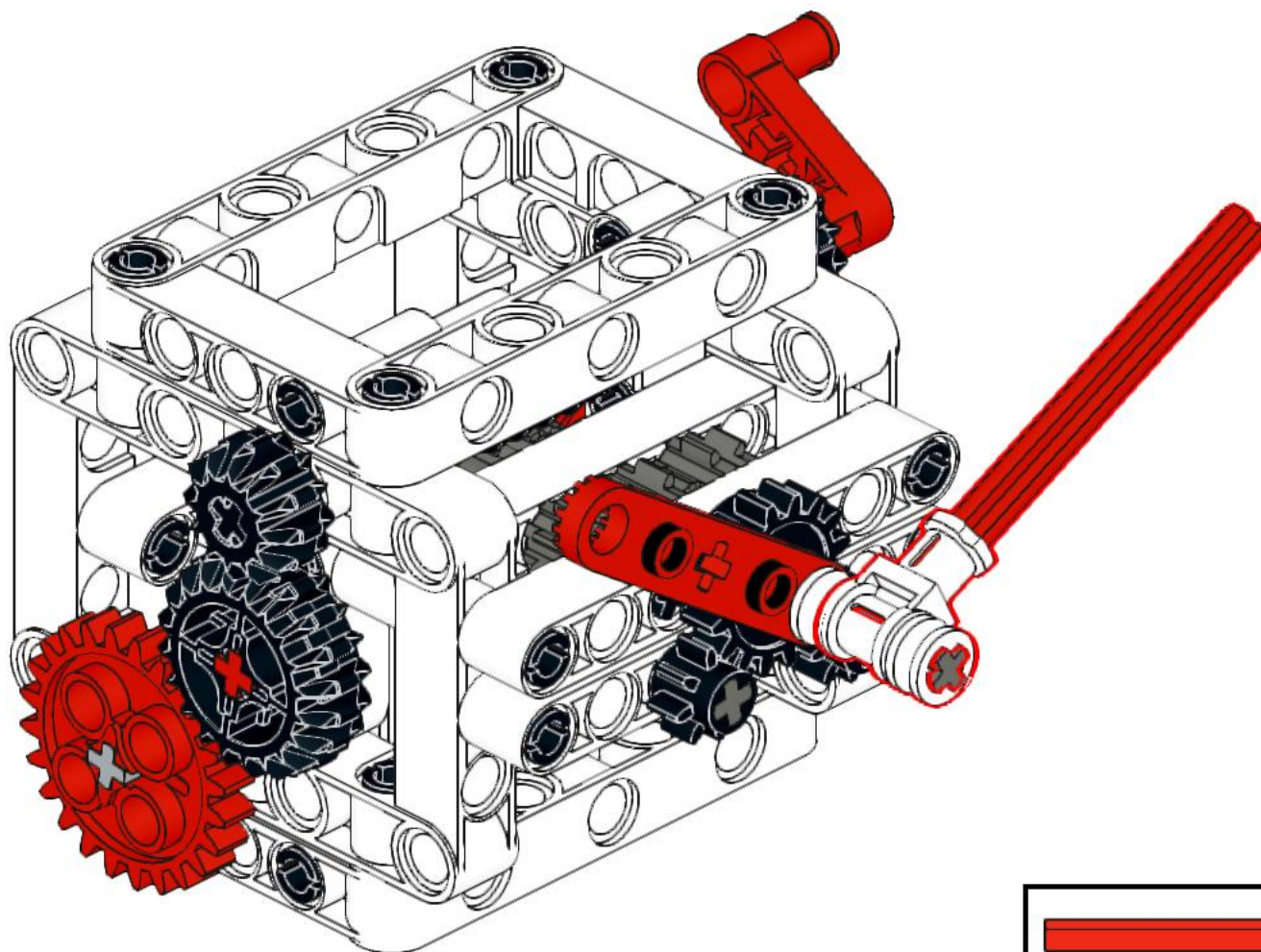
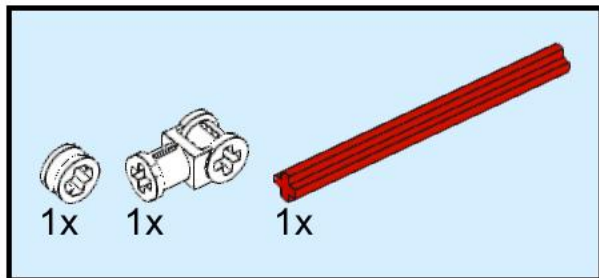

# 29

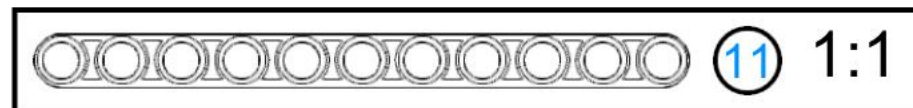
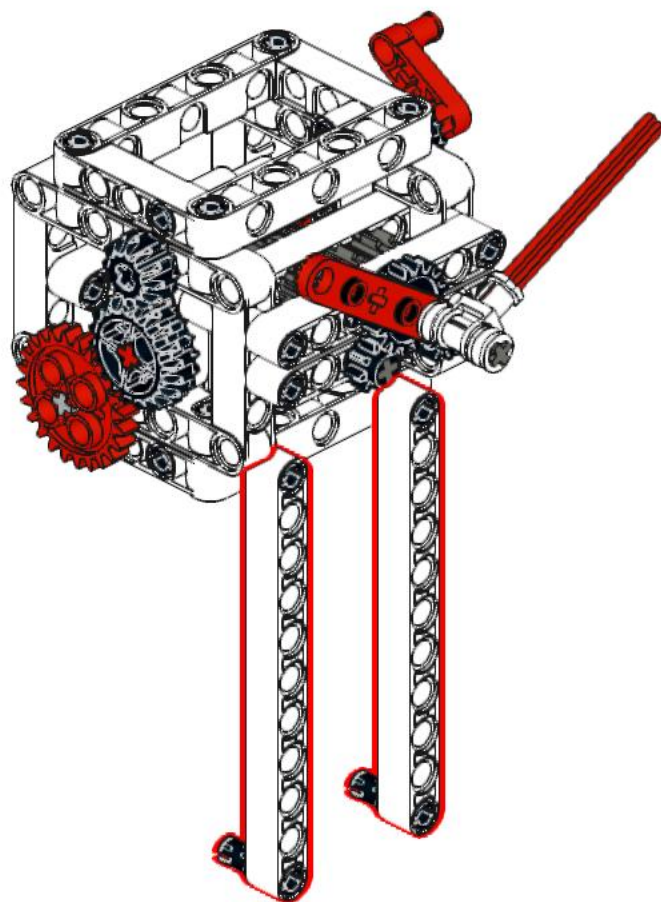
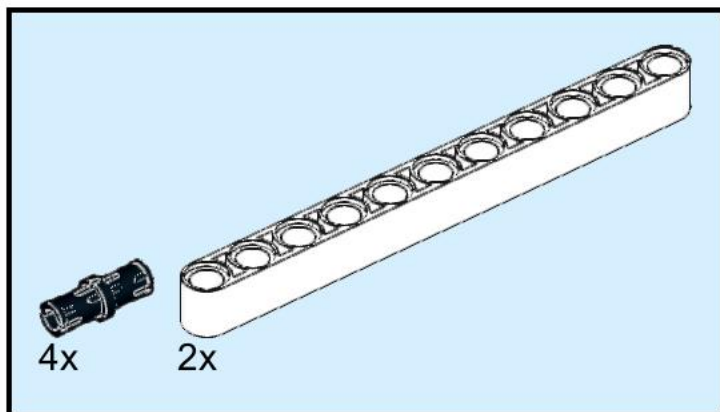

# 30

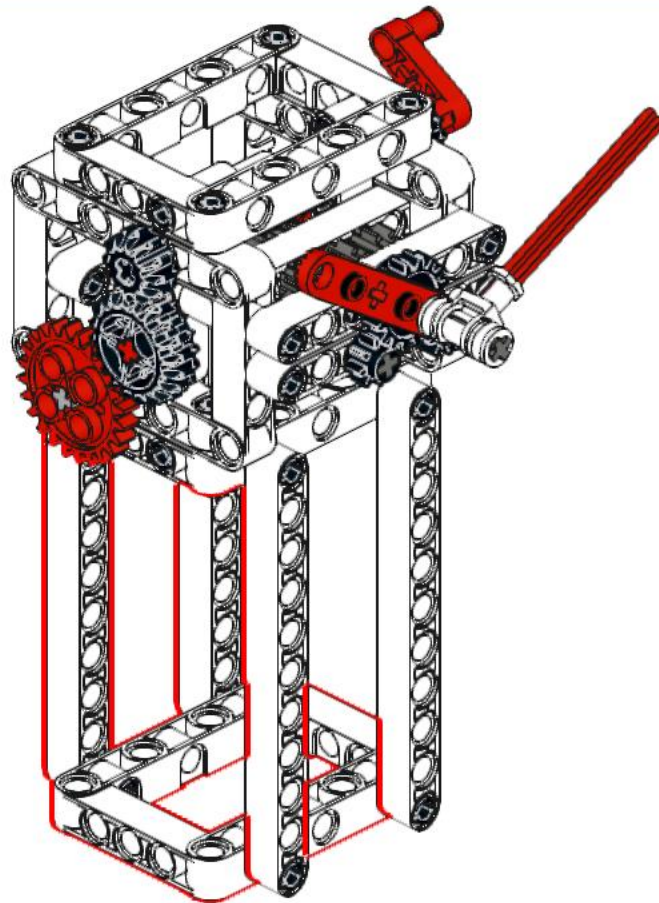
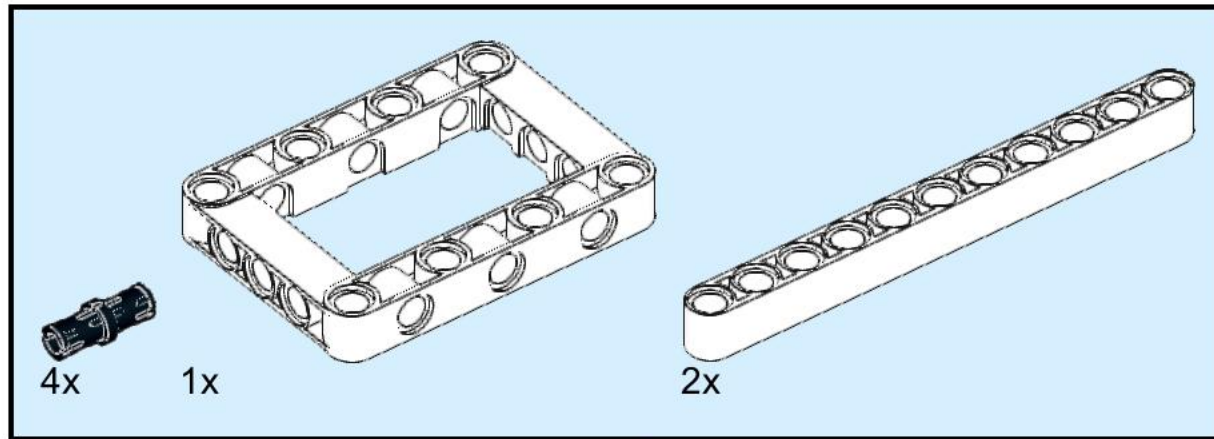

# 31

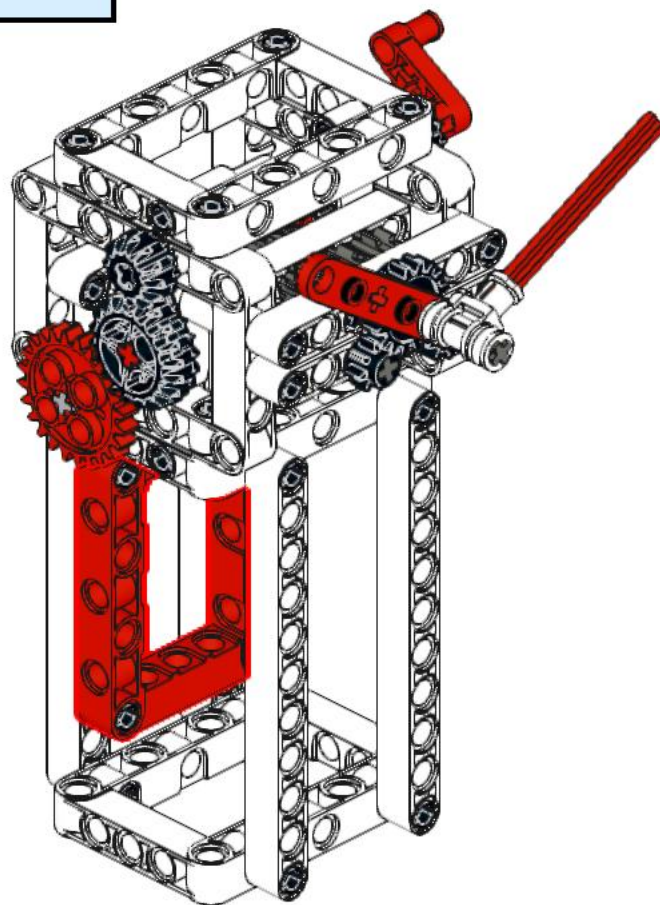
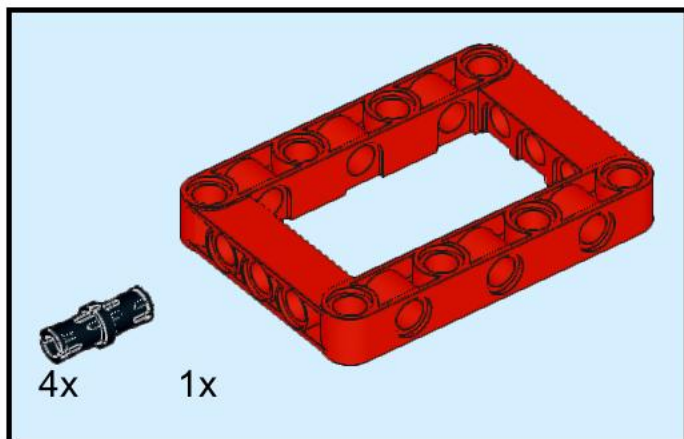



2x  
3647  
Black



1x  
6542  
Black



32x  
2780  
Black



2x  
32269  
Black



2x  
32270  
Black



2x  
4716  
Black



1x  
3737  
Black



2x  
6558  
Black



4x  
10928  
Dark Bluish Gray



2x  
18651  
Black



1x  
3648  
Dark Bluish Gray



2x  
55013  
Dark Bluish Gray



1x  
4519  
Light Bluish Gray



1x  
60485  
Light Bluish Gray



7x  
4265c  
White



1x  
32039  
White



2x  
32523  
White



6x  
32524  
White

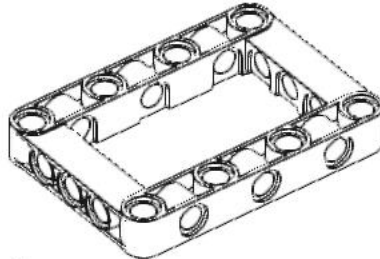

5x  
64179  
White

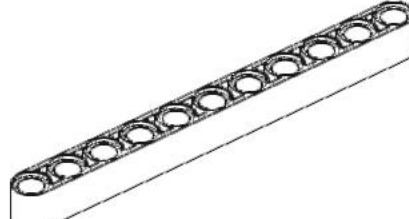

4x  
32525  
White



3x  
3713  
Red



2x  
62462  
Red



2x  
11214  
Red



1x  
61408  
Red



2x  
3648  
Red



1x  
2711  
Red



1x  
3706  
Red

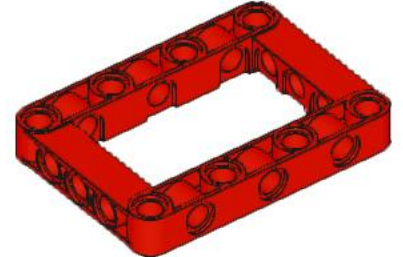

1x  
64179  
Red